

Schematic Lighting Strategy (Detailed Planning Application)
THE EDGE, GREAT YARMOUTH



March 2008

Introduction

This document sets out scheme design proposals for the exterior lighting of The Edge in Great Yarmouth. The development is situated next to the existing Pleasure Beach and its intention is to attract large numbers of visitors to the area.

The external lighting scheme will focus attention to the development and create interest. The Edge can be seen from viewpoints all around the site which was a major consideration when determining the lighting approach. The development will be predominantly used at night so the external lighting scheme will add a significant impact to the feel of the area.



Main viewpoints



Great Yarmouth by night

Lighting Concept

The lighting concept for The Edge can be split into 5 main components:-

1. Façade lighting – West Elevation (Street Side)
2. Façade lighting – East Elevation (Seaside)
3. 'Walk-through' lighting
4. Pedestrian lighting
5. Car park façade lighting

As a large area of the complex is architecturally closed our aim is to make the functions of the spaces on the inside visible on the outside with light. By using dynamic coloured lighting we can make it clear to all that behind the closed façade a world of excitement and fun is waiting.

The following pages describe the lighting approach for each of the five components which makes up the complete visual scene



view from street side



elevation from the sea

Facade Lighting Concept

The most striking architectural elements of the complex are the large panels that clad the outside of the building.

We have merged the elements **brightness** and **movement** in the lighting concept for the facade using these panels

Day

During the day the facade panels are large reflective surfaces which are revealed by daylight and sunlight.

Night

At night these reflective panels will be lost if left unlit however they can become reflective surfaces for a dynamic lighting effect that will enthrall all who see it.

By using colour changing and movement the eye is drawn to the facade and it is made clear that something interesting is happening here.



Panels during the day – we recommend the panels to be rendered in a light colour.



Panels by night – the panels are lit with colour changing lighting

Facade Lighting –Street side (West Elevation)

The facade panels on the west elevation are to be lit with linear, colour changing LED strips mounted at a close offset to the panel. This creates a 'grazing' light effect. This gradation can be used to draw visitors towards the entrance. The LED itself is a bright light source and it is proposed that the strips be located on the panel edge that is furthest from the development entrance to minimise any glare as people enter the walk through area.

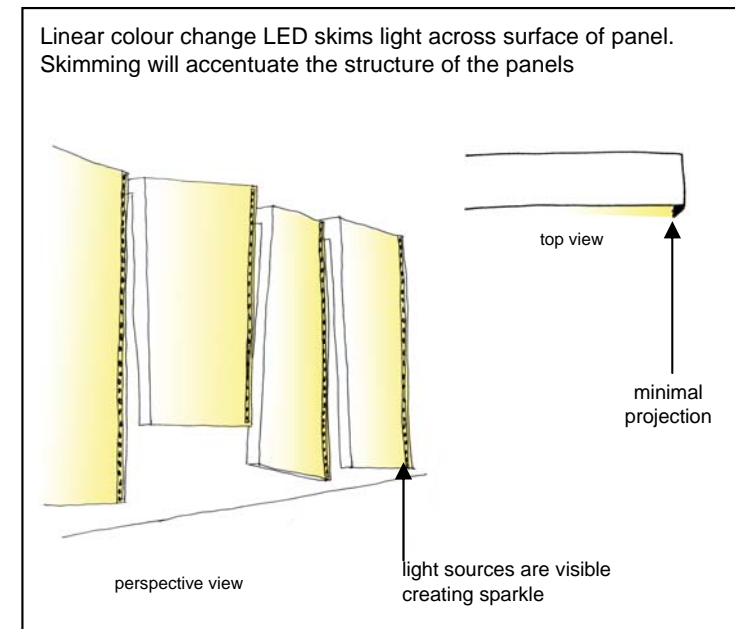
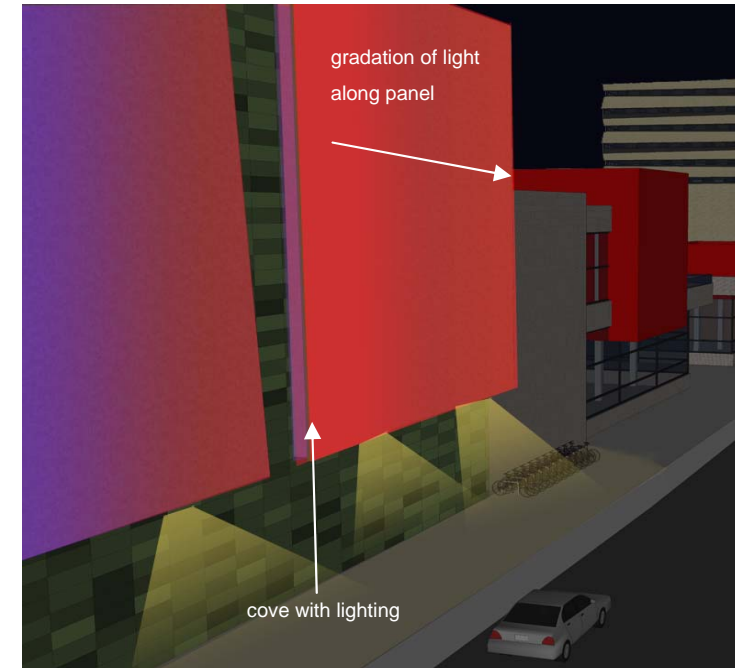

Façade Lighting – Street side (West Elevation)

To achieve the grazing effect it is proposed that a linear LED fixture such as Crescent Lighting's CLOptic be employed. This has an oval beam (8 x 25°) distribution creating a wide wash of light on the façade whilst limiting any light spill.

The luminaire has a minimal cross section and contains 1W luxeon LEDs alternating red, green and blue. Any colour can be achieved by mixing the LEDs.

The luminaires are to be mounted vertically along one side of each panel. The luminaires are resin filled to IP66 for external use.

They are to be concealed within an edge profile to create a neat detail that conceals not only the luminaire itself but the associated wiring and any connections. The sketch shows the minimum dimensions for the edge profile to allow a degree of adjustment of the fitting. The LED strips are to have rear entry cables to ensure they can be butted together to create a continuous line of light. The profile can be colour matched to the façade to minimise its obtrusiveness during the daytime.

Using an LED source has the advantage of low power consumption, long life and low maintenance.

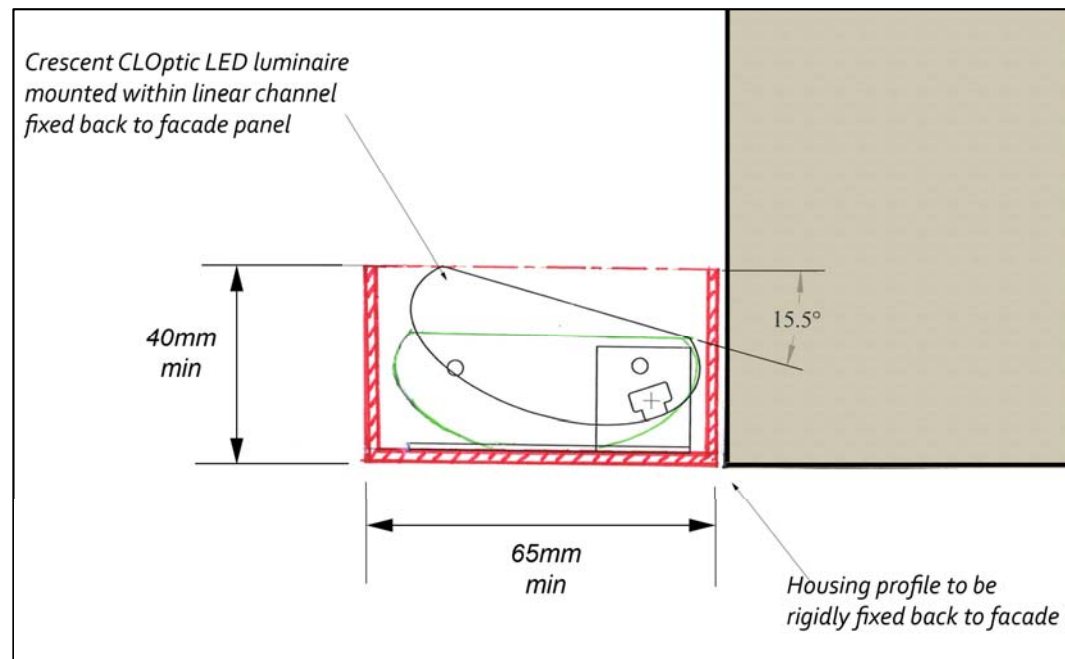

LED strip mounted in linear housing

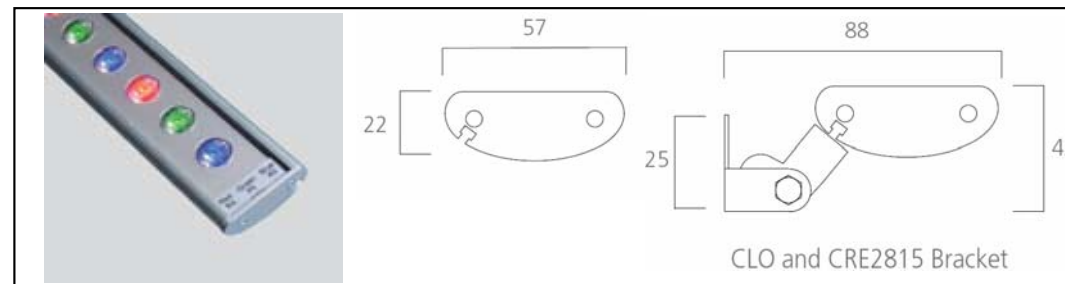

Crescent CLOptic

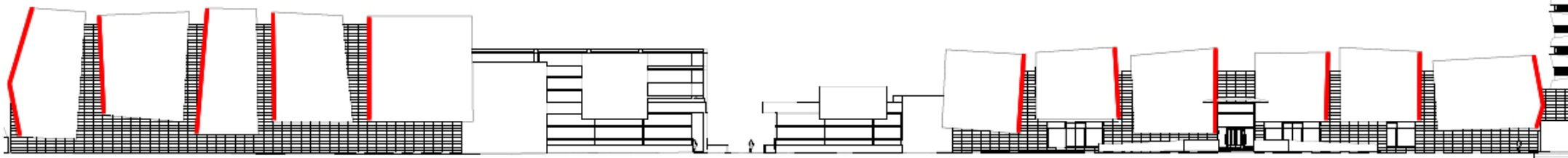

concealed LED strip washing panels

Façade Lighting Seaside (East Elevation)

The intention on the sea facing elevation is to provide a stronger colour changing wash of light on the façade panels. This will be achieved by directly lighting the surface using directional LED luminaires concealed within lighting columns.

When the number of lighting columns is kept to a minimum the aesthetic of the promenade is greatly enhanced. The lighting column is to be a custom made product that fulfils two purposes. It will incorporate both the façade lighting and street lighting components.

The lighting columns are to be located at the edge of the promenade, to gain the maximum offset, and are to be spaced at 8m centres. Adjustable LED floodlights will be mounted within the column to evenly light the façade. The offset and spacing is determined to ensure an even wash of light onto the panels and the required lighting level and distribution on to the pavement.

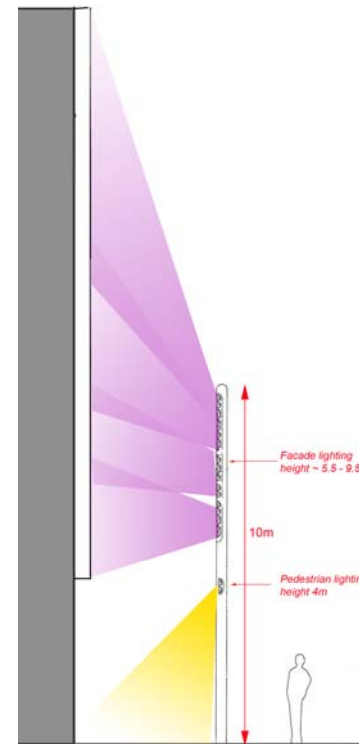
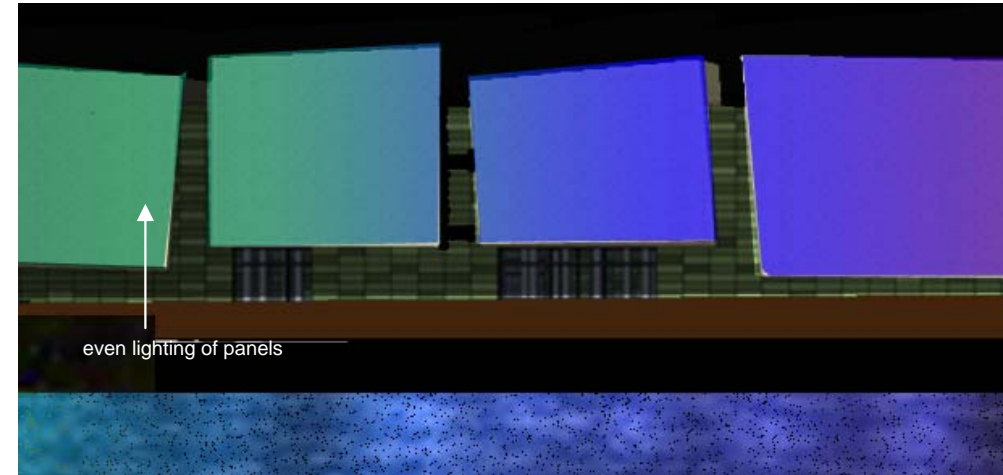

Section showing light column in relation to facade

Façade Lighting Seaside (East Elevation)

The lighting column is to be approximately 10m tall. The façade lighting component will be located within the top half of the lighting column at a height between approximately 5.5 and 9.5m. In order to light the façade evenly a number of LED projector units with varying beam distributions will be mounted within this section of the lighting column. Each will be focused onto a specific area of the façade.

The pedestrian lighting will be provided by 20W ceramic metal halide projectors mounted at approximately 4m. The projectors are to have linear spreader lenses to create an elongated beam to light the walkway. The beam will have a sharp cut off to ensure there is no spill light on to the façade.

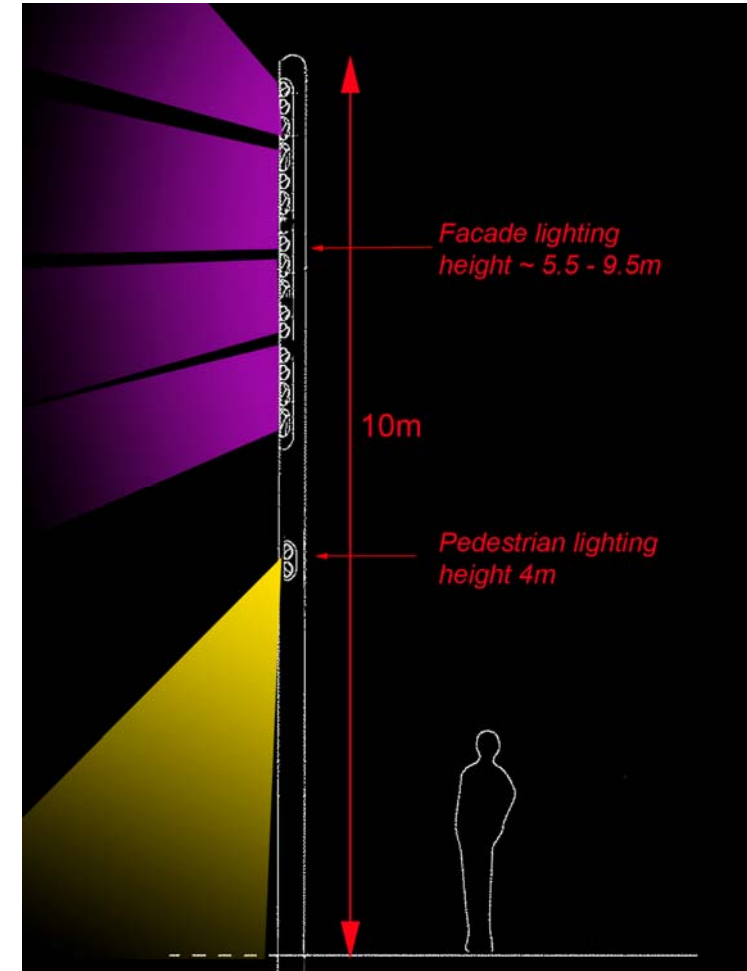
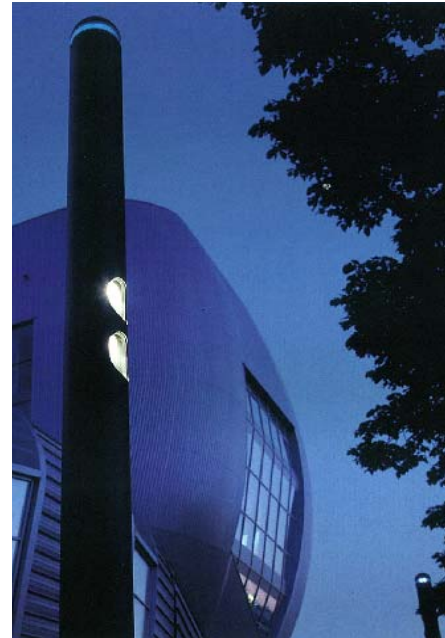

Philips 'Multipole' - bespoke lighting column containing adjustable LED projectors/metal halide downlight

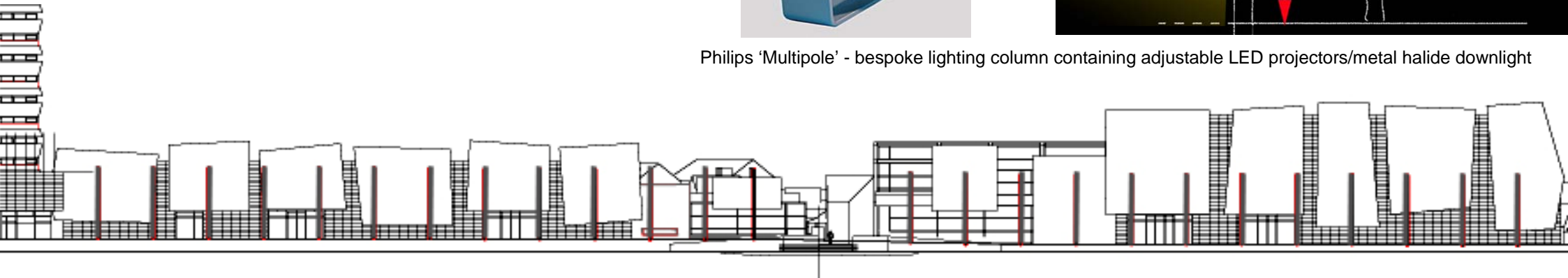

Column spacing at 8m centres

Walk through lighting

Decorative feature pendants are to be introduced in the walk through space to create visual interest and vibrancy.

High voltage cold cathode is to be formed into 'decorative chandeliers' which appear to be floating in the space. This can be achieved by mounting them to a catenary wire system which spans between the adjacent buildings.

The cold cathode can be formed into any shape and a wide variety of colours are available. The 'chandeliers' will not only be light sculptures but will provide the functional light required in the space without having to introduce additional luminaires.

The catenary system supporting the chandeliers will 'disappear' at night whilst appearing very minimal and unobtrusive during the day.

The control gear for the cold cathode can be mounted remotely.

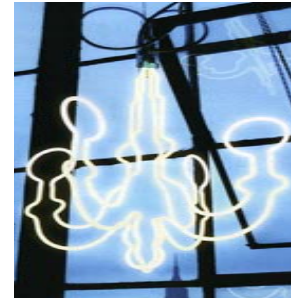

High voltage cold cathode light sculptures by night and by day



Catenary support structure by day and night

Pedestrian lighting

The promenade on the sea side and the pavement on the street side are to be lit to an average illumination level of 15lux. This is to be achieved in two distinct ways.

Street side

The walkway along the street is to be lit by recessed downlights set into the underside of the façade panels. An adjustable fitting will be used to minimise any light spill back onto the façade. However it is still recommended that the brick work under the panels be dark to minimize reflection.

An under canopy downlight with a 20W ceramic metal halide lamp and linear spreader lens is to be employed. The downlights are to be at 8m spacings but can be adjusted slightly to work with the panel widths.

Sea side

As previously described the pathway will be lit by 20W ceramic metal halide sources mounted within the bespoke lighting column.

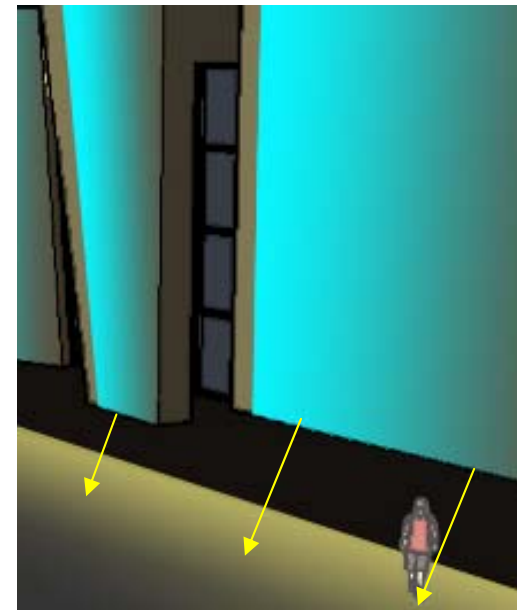
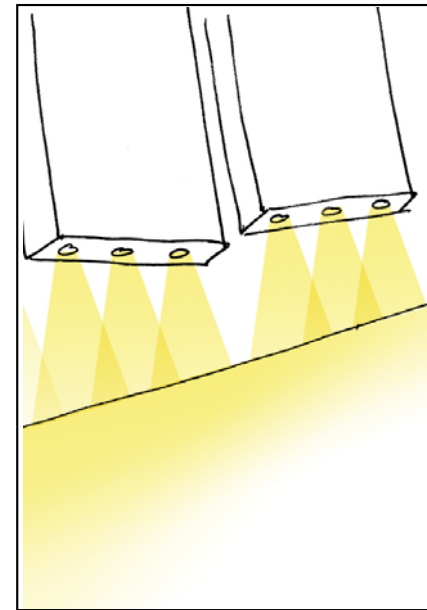
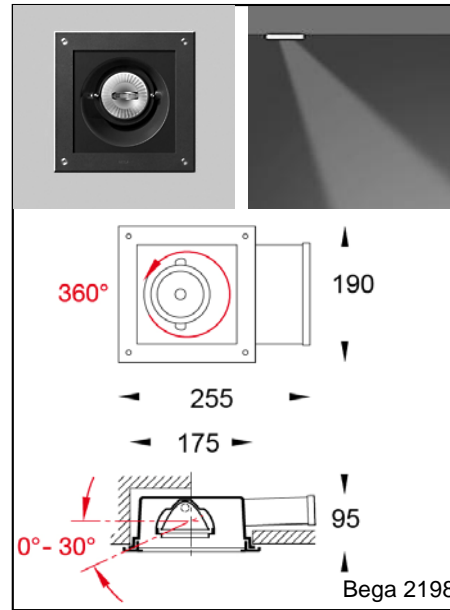

Under canopy adjustable downlight providing pavement lighting

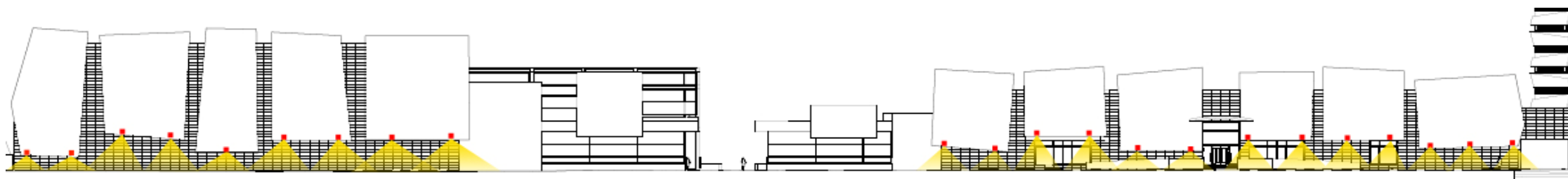

■ under canopy downlight

Car park facade lighting

The car park is to be clad with timber screens. These screens are perforated therefore the interior of the car park and its associated lighting will be visible from the outside. During the day the timber screens will be revealed by natural light however at night they will fall into silhouette if left unlit.

It is proposed that ground recessed 35W ceramic metal halide uplights are to be used to create a soft wash of light up the timber panelling revealing its texture. The luminaires are to be installed at 4m centres and at an offset of approximately 2m. The luminaire is to be specified with anti vandal screws and an internal glare louvre.

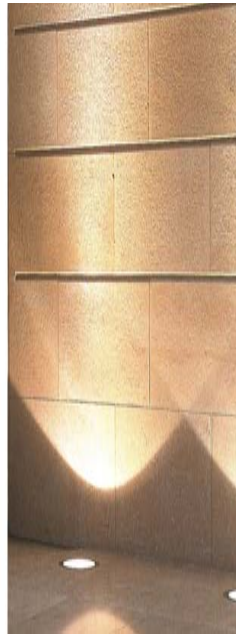

In ground uplighters providing soft wash of light revealing timber screen

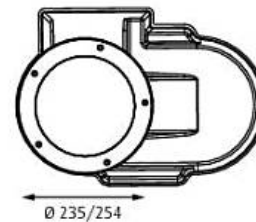
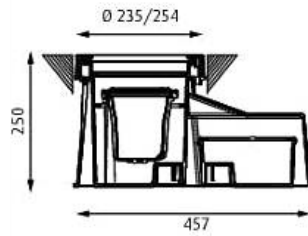

Recessed CDM uplight

Avoid strong silhouette

Contact

ArupLighting

13 Fitzroy Street
W1T 4BQ London

florence.lam@arup.com
katie.davies@arup.com